

Pull rings, galvanised

Technical catalogue: Duct systems
 Section: 05
 Page: 1/2
 Revised: 01.05.2009

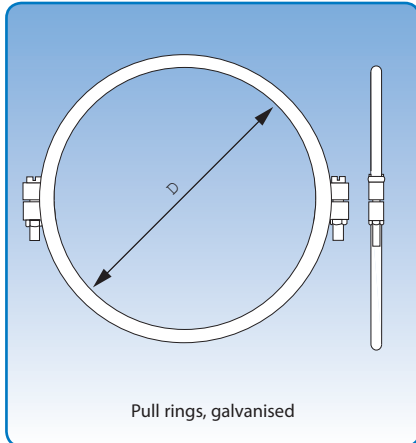

Diameter: $\varnothing 80 - \varnothing 500$ mm.
 Galvanised pull rings [f.b] are in two pieces.
 Pull rings are electro-galvanised.
 EPDM rubber rings are available as optional extras for sealing $\varnothing 80 - \varnothing 300$ mm diameter assemblies.

They are supplied in plastic bags of 10, along with the necessary nuts and bolts.

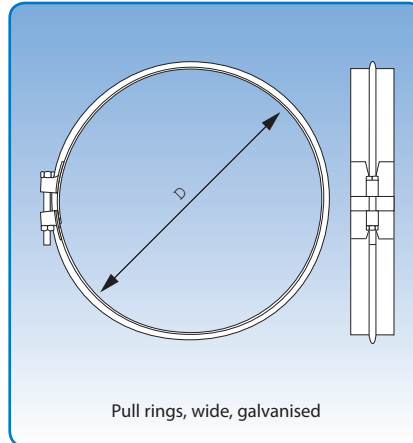

Diameter: $\varnothing 150 - \varnothing 800$ mm.
 Wide galvanised pull rings [f.bb] are made from hot dip galvanised sheet metal.

These rings are supplied individually with nuts and bolts.

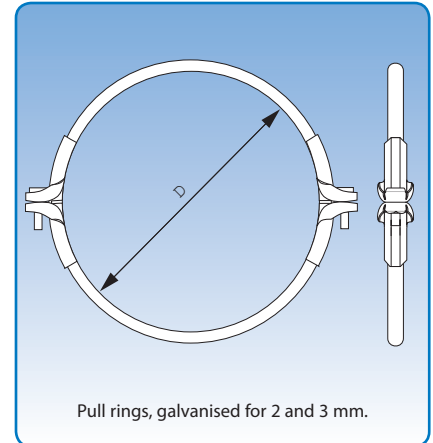

Diameter: $\varnothing 80 - \varnothing 600$ mm.
 Galvanised pull rings [f.b] are in two pieces.
 Pull rings are electro-galvanised.

Insert with sealing compound

JKF supplies pull rings with sealing compound inserted, made of Terostat VII material. The insert has a protective plastic film which must be removed before the pull ring can be used. The sealing compound is not soluble. Working temperature range is -50°C to $+100^{\circ}\text{C}$. The rings are supplied in plastic bags of 10, along with the necessary nuts and bolts.

Pull rings, galv.		
Item no.	D mm	10 pcs. Weight kg
1670011	80	0,55
1671011	100	0,60
1672011	120	0,65
1673011	125	0,70
1674011	140	0,75
1675011	150	0,80
1676011	160	0,83
1677011	180	0,85
1678011	200	0,90
1679011	225	0,95
1680011	250	1,00
1680511	275	1,05
1681011	300	1,25
1682011	315	1,30
1682611	325	1,30
1683011	350	1,35
1684011	400	1,45
1684711	425	1,50
1685011	450	1,65
1686011	500	1,90

Pull rings, wide, galvanised.		
Item no.	D mm	Pce. Weight kg
1675001	150	0,22
1676001	160	0,23
1677001	180	0,24
1678001	200	0,25
1679001	225	0,30
1680001	250	0,35
1680501	275	0,40
1681001	300	0,45
1682001	315	0,47
1682601	325	0,49
1683001	350	0,50
1683701	375	0,52
1684001	400	0,55
1684701	425	0,55
1685001	450	0,60
1685901	475	0,60
1686001	500	0,65
1686501	525	0,67
1687001	550	0,70
1688001	600	0,75
1689001	630	0,78
1690001	650	0,80
1691001	700	0,86
1692001	750	0,90
1693001	800	0,98

Pull rings, 2 and 3 mm, galv.		
Item no.	D mm	10 pcs. Weight kg
Rubber ring insert (EPDM)		
1670021	80	1,76
1671021	100	1,87
1672021	120	2,04
1673021	125	2,21
1674021	140	2,25
1675021	150	2,38
1676021	160	2,55
1677021	180	2,72
1678021	200	2,83
1679021	225	3,20
1680021	250	3,40
1680521	275	3,45
1681021	300	3,57
Insert with sealing compound		
1682021	315	4,25
1683021	350	4,42
1684021	400	4,93
1685021	450	5,61
1686021	500	6,46
1687021	550	7,14
1688021	600	8,50