

# Flour Milling

## VFS Butterfly Valves



27



### Description ▼

VFS Butterfly Valves consist of two high-pressure die-cast semi-bodies manufactured from aluminium alloy, a swivel disc in stainless steel or cast iron, and a pre-stressed elastomer seal or an integral seal.

While V1FS has a top flange and a beaded bottom section suitable for the attachment of a flexible sleeve, the V2FS comes with an identical top and bottom flange.

### Function ▼

For closing bins, hoppers and silos containing powders or granular materials, VFS Butterfly Valves are among the most widely used equipment worldwide.

What used to be custom-built items for specific applications, have been turned by WAM® into a mass-produced industrial product with features that allow extremely versatile use.



### Applications ▼

VFS Butterfly Valves are used in all types of flour mills where interception of gravity-fed or pneumatically conveyed dry materials is required.

Typical applications are storage, transport and processing lines. They are fitted beneath hoppers, bins, silos, screw or other type conveyors, or to intercept pneumatic conveying ducts. Due to their special design and to the engineering materials used, they represent a particularly cost-effective yet most efficient solution.

### Benefits ▼

- ✓ **No contamination due to metal steel disc and NBR white seal;**
- ✓ **Dust-tight thanks to components geometry;**
- ✓ **Suitable for different materials in the same configuration;**
- ✓ **Safety for OEM and end user thanks to ATEX zone 22 certification;**
- ✓ **Quick integration into the process;**
- ✓ **Modular design and easy maintenance thanks to small numbers of components;**
- ✓ **High flexibility thanks to interchangeable components.**



[www.wamgroup.com](http://www.wamgroup.com)

# Flour Milling

## VFS Butterfly Valves



### Technical Features / Performance ▼

- ▶ V1FS with top flange and beaded bottom section suitable for fixing of flexible sleeve from 100 ~ 400 mm (4 in ~16 in)
- ▶ V2FS with identical top and bottom flange from 100 ~ 400 mm (4 in ~16 in)
- ▶ Pressure-proof up to 0.2 bar (2.9 psi) and max temperature T = 100°C (212°F)
- ▶ Disc in SINT® engineering polymer FDA-approved, or stainless steel
- ▶ Absence of stagnation points
- ▶ White seals for standard or no contact with product application
- ▶ Interchangeable discs

### Overall Dimensions ▼

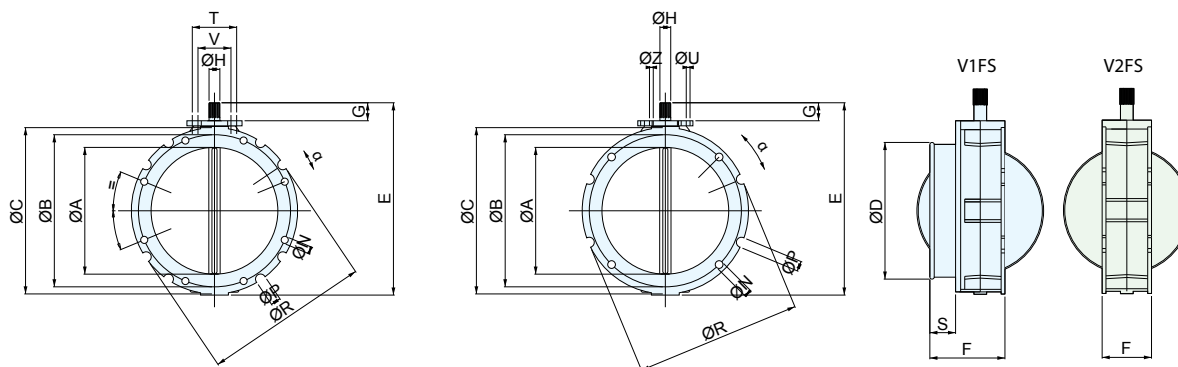

TYPE	Ø A	Ø B	Ø C	Ø D	E	F	G	Ø H DIN 5482	N Drilling	P External grooves	Ø R	α	S	T	U	V	Z	KR
V1FS 100.	95	180	220	105	250	115	35	22x19	N°4 x Ø14	N°4 x Ø20	220	22°30'	40	80	M12	50	M10	4
V1FS 150.	150	200	228	163	290	115	35	22x19	N°4 x Ø14	N°4 x Ø20	228	22°30'	40	80	M12	50	M10	5
V1FS 200.	200	250	278	213	340	115	35	22x19	N°4 x Ø14	N°4 x Ø20	278	22°30'	40	80	M12	50	M10	6.5
V1FS 250.	250	300	328	263	390	115	35	22x19	N°8 x Ø14	N°8 x Ø20	325	11°15'	40	80	M12	50	M10	7.5
V1FS 300.	300	350	378	313	440	115	35	22x19	N°8 x Ø14	N°16 x Ø20	375	5°41'	40	80	M12	50	M10	9
V1FS 350.	350	400	440	363	530	123	50	28x25	N°8 x Ø14	N°8 x Ø20	440	10°	40	80	M12	-	-	16
V1FS 400.	400	470	530	413	580	123	50	28x25	N°8 x Ø14	N°16 x Ø20	530	4°30'	40	80	M12	-	-	20.5

Dimensions in mm

TYPE	Ø A	Ø B	Ø C	E	F	G	Ø H DIN 5482	N Drilling	P External grooves	Ø R	α	T	U	V	Z	KR
V2FS 100.	95	180	220	250	77	35	22x19	N°4 x Ø14	N°4 x Ø20	220	22°30'	80	M12	50	M10	4
V2FS 150.	150	200	228	290	77	35	22x19	N°4 x Ø14	N°4 x Ø20	228	22°30'	80	M12	50	M10	5
V2FS 200.	200	250	278	340	77	35	22x19	N°4 x Ø14	N°4 x Ø20	278	22°30'	80	M12	50	M10	6.5
V2FS 250.	250	300	328	390	77	35	22x19	N°8 x Ø14	N°8 x Ø20	325	11°15'	80	M12	50	M10	7.5
V2FS 300.	300	350	378	440	77	35	22x19	N°8 x Ø14	N°16 x Ø20	375	5°41'	80	M12	50	M10	9
V2FS 350.	350	400	440	530	85	50	28x25	N°8 x Ø14	N°8 x Ø20	440	10°	80	M12	-	-	16
V2FS 400.	400	470	530	580	85	50	28x25	N°8 x Ø14	N°16 x Ø20	530	4°30'	80	M12	-	-	20.5

Dimensions in mm

*This datasheet might not show the complete range but only the models most suitable for the application.*