

Paint & Varnish Processing

Drop-Through Rotary Valves RVSC



24



Description ▼

RVS Blow-Through Rotary Valves consist of a tubular cast iron or stainless steel casing, a horizontally mounted rotor with a certain number of oblique V-shaped cross section compartments, a drive unit and a casing cover at each end.

Function ▼

Two compartments at a time of the continuously turning rotor are filled up with material through the inlet at the top of the Rotary Valve. After less than half a turn the material falls through the bottom opening into an air stream passing through a pneumatic conveying duct connected with the bottom part of the Rotary Valve.



Application ▼

RVS Blow-Through Rotary Valves are usually fitted at the outlet of a bin, silo or hopper upstream of a pneumatic conveying duct into which the material is accurately fed.

Benefits ▼

- ✓ **Material: cast iron, SS, coating, chromed body and various rotor versions available to offer the ideal configuration for most application requirements;**
- ✓ **Pipe connections included simplifying unit installation and removal.**

Paint & Varnish Processing

Drop-Through Rotary Valves RVSC



Technical Features / Performance ▼

- ▶ Feed rates: 5, 9, 14, 20, 38, 80 litres per revolution (0.17, 0.3, 0.5, 0.7, 1.3, 2.8 cu ft per revolution)
- ▶ Working temperature: -20 °C ~ 220 °C (-4° F ~ 428° F)
- ▶ Maximum differential pressure: 0.8 bar (11.6 psi)
- ▶ Cast iron or 304 SS
- ▶ Nickel coating available
- ▶ Rotor with beveled blades or replaceable tips
- ▶ Chrome-plated casing for abrasive materials
- ▶ Sturdy compact structure
- ▶ Small footprint
- ▶ Drive unit mounted directly on shaft without any further bearing assembly or coupling
- ▶ Rectangular inlet flanges
- ▶ Counterflanges to be welded on pneumatic conveying duct
- ▶ Blade scraper installed inside the inlet to ease rotor movement

Overall Dimensions ▼

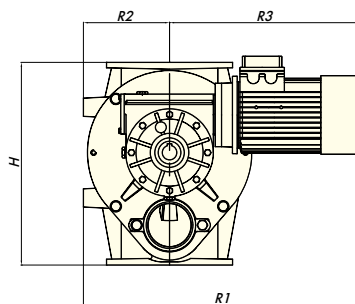
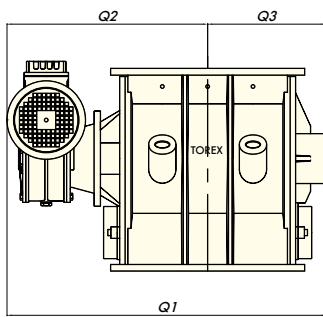

	TYPE	Dimensions in mm						Electric Motor		
		Q1	Q2	Q3	R1	R2	R3	H	kW	min ⁻¹
30 RPM	RVS/C 05	505	342	163	550	130	420	335	0.55	1,400
	RVS/C 10	572	372	200	560	140	420	339	0.75	1,400
	RVS/C 15	605	390	215	588	162	426	399	1.1	1,400
	RVS/C 20	705	444	261	608	181	426	447	1.5	1,400
	RVS/C 35	890	558	332	740	217	523	530	2.2	1,400
	RVS/C 80	1,165	718	447	890	277	613	677	3	1,400

	TYPE	Dimensions in mm						Electric Motor		
		Q1	Q2	Q3	R1	R2	R3	H	kW	min ⁻¹
20 RPM	RVS/C 05	505	342	163	550	130	420	335	0.55	900
	RVS/C 10	572	372	200	560	140	420	339	0.55	900
	RVS/C 15	605	390	215	588	162	426	399	0.75	900
	RVS/C 20	705	444	261	608	181	426	447	1.1	900
	RVS/C 35	890	558	332	740	217	523	530	1.5	900
	RVS/C 80	1,165	718	447	883	277	556	677	2.2	900

	TYPE	Dimensions in mm						Electric Motor		Pre-Torque	
		Q1	Q2	Q3	R1	R2	R3	H	kW		min ⁻¹
10 RPM	RVS/C 05	475	342	163	517	130	387	335	0.37	1,400	YES
	RVS/C 10	542	342	200	527	140	387	339	0.37	1,400	YES
	RVS/C 15	585	370	215	572	162	410	399	0.55	1,400	YES
	RVS/C 20	658	397	261	591	181	410	447	0.75	1,400	YES
	RVS/C 35	890	558	332	740	217	523	530	1.1	1,400	NO
	RVS/C 80	1,150	703	447	832	277	555	677	1.5	1,400	NO

DS_RVSC.CH, September 2015, R00 Rights reserved to modify technical specifications.

This datasheet might not show the complete range but only the models specialised for the application.



www.wamgroup.com