

# Pasta Processing Plant

## RVS Blow-Through Rotary Valves

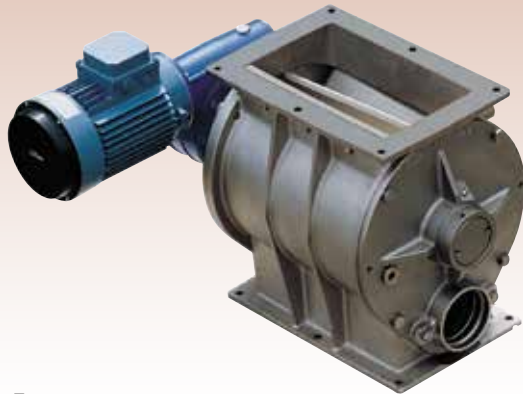

4



### Description ▼

RVS Blow-Through Rotary Valves consist of a tubular cast iron or stainless steel casing, a horizontally mounted rotor with a certain number of oblique V-shaped cross section compartments, a drive unit and a casing cover at each end.

### Function ▼

Two compartments at a time of the continuously turning rotor are filled up with material through the inlet at the top of the Rotary Valve. After less than half a turn the material falls through the bottom opening into an air stream passing through a pneumatic conveying duct connected with the bottom part of the Rotary Valve.



### Application ▼

RVS Blow-Through Rotary Valves are usually fitted at the outlet of a bin, silo or hopper upstream of a pneumatic conveying duct into which the material is accurately fed.

### Benefits ▼

- ✓ No product contamination due to 304/316 SS design and air-injected seals;
- ✓ Zone 22 ATEX-certified;
- ✓ 304 SS inserts for granules;
- ✓ Cast iron or 304/316 SS material, nickel coating and various other rotor versions available to offer the best configuration for most application requirements;
- ✓ Pipe connections already included simplify unit installation and removal.

# Pasta Processing Plant

## RVS Blow-Through Rotary Valves



### Technical Features / Performance ▼

- ▶ Feed rates: 5, 9, 14, 20, 38 litres per revolution (0.17, 0.3, 0.5, 0.7, 1.3 cu ft per revolution)
- ▶ Working temperature: -20°C to 150°C (-4°F to 240°F)
- ▶ Maximum differential pressure: 0.8 bar (11.6 PSI)
- ▶ Cast iron or 304/316 SS
- ▶ Nickel coating available
- ▶ Rotor with bevelled blades
- ▶ Easy access to internal mechanical parts
- ▶ Sturdy compact structure
- ▶ Small footprint
- ▶ Drive unit mounted directly on shaft without any further bearing assembly or coupling
- ▶ Rectangular inlet flanges
- ▶ Counterflanges to be welded on pneumatic duct
- ▶ Blade scraper installed inside the inlet to ease rotor movement
- ▶ Different materials and treatments available depending on material handled

### Overall Dimensions ▼

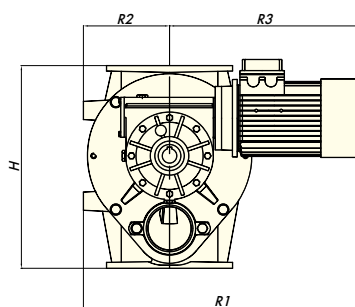
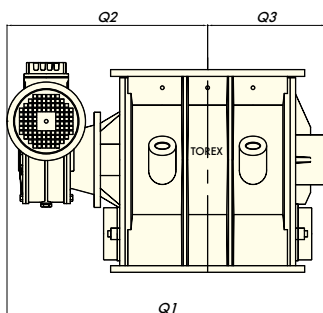

	TYPE	Dimensions in mm							Electric Motor	
		Q1	Q2	Q3	R1	R2	R3	H	kW	min <sup>-1</sup>
30 RPM	RVS/C 05	505	342	163	550	130	420	335	0.55	1,400
	RVS/C 10	572	372	200	560	140	420	339	0.75	1,400
	RVS/C 15	605	390	215	588	162	426	399	1.1	1,400
	RVS/C 20	705	444	261	608	181	426	447	1.5	1,400
	RVS/C 35	890	558	332	740	217	523	530	2.2	1,400
	RVS/C 80	1,165	718	447	890	277	613	677	3.0	1,400

	TYPE	Dimensions in mm							Electric Motor	
		Q1	Q2	Q3	R1	R2	R3	H	kW	min <sup>-1</sup>
20 RPM	RVS/C 05	505	342	163	550	130	420	335	0.55	900
	RVS/C 10	572	372	200	560	140	420	339	0.55	900
	RVS/C 15	605	390	215	588	162	426	399	0.75	900
	RVS/C 20	705	444	261	608	181	426	447	1.1	900
	RVS/C 35	890	558	332	740	217	523	530	1.5	900
	RVS/C 80	1,165	718	447	883	277	556	677	2.2	900

	TYPE	Dimensions in mm							Electric Motor		Pre-Torque
		Q1	Q2	Q3	R1	R2	R3	H	kW	min <sup>-1</sup>	
10 RPM	RVS/C 05	475	342	163	517	130	387	335	0.37	1,400	YES
	RVS/C 10	542	342	200	527	140	387	339	0.37	1,400	YES
	RVS/C 15	585	370	215	572	162	410	399	0.55	1,400	YES
	RVS/C 20	658	397	261	591	181	410	447	0.75	1,400	YES
	RVS/C 35	890	558	332	740	217	523	530	1.1	1,400	NO
	RVS/C 80	1,150	703	447	832	277	555	677	1.5	1,400	NO

*This datasheet might not show the complete range but only the models specialised for the application.*