

Slide Gate Valves VL

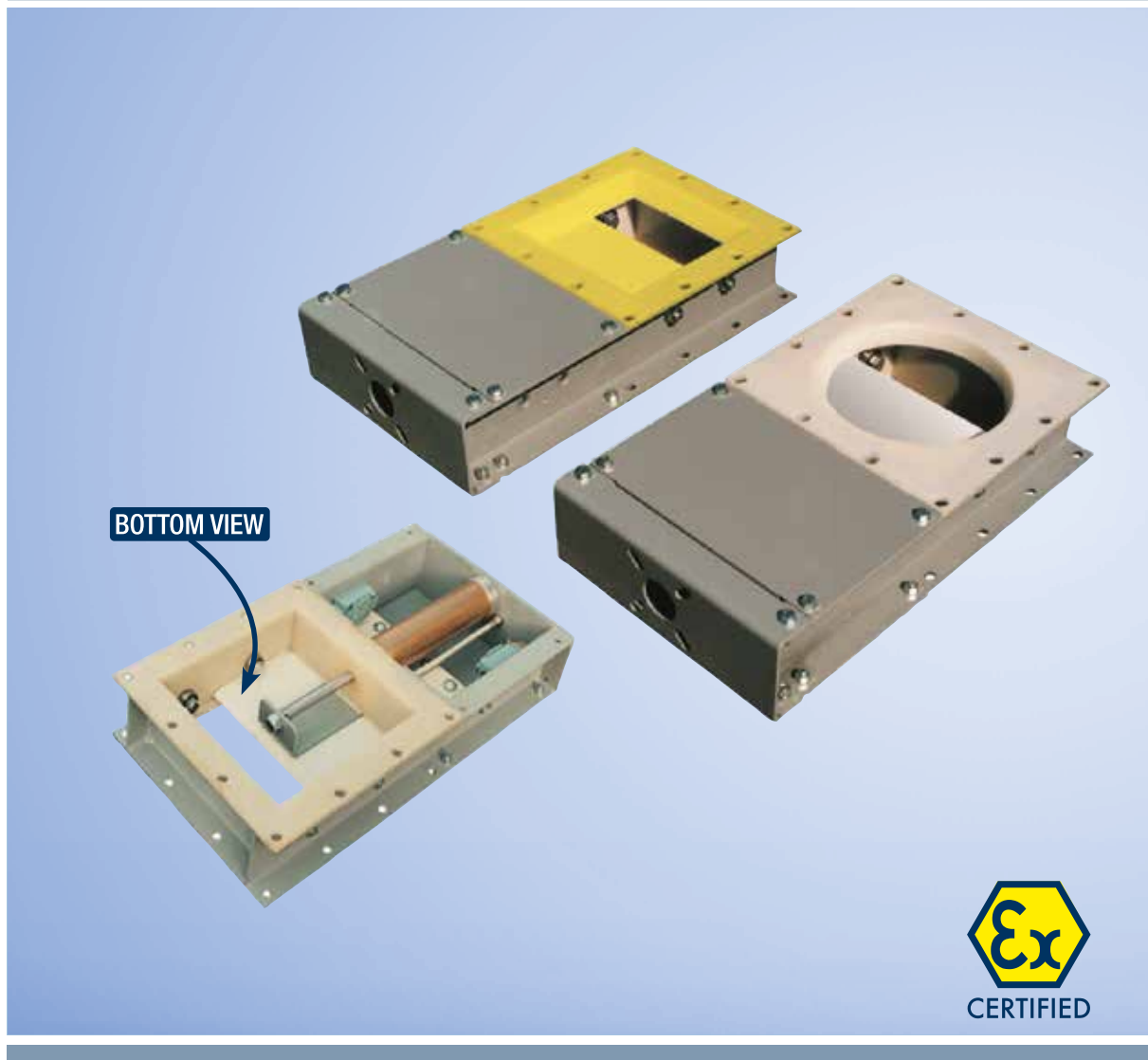

FLOW INTERCEPTION WITH UNIQUE DESIGN FEATURES

The wide use of WAMGROUP®'s special SINT® engineering polymer in designing the VL range makes these Slide Gate Valves the ideal equipment for intercepting the flow of powdery or granular materials in gravity or conveying applications.

The special geometry of VL Slide Gate Valves and the various options in blade design enable their application in virtually all industries including food processing.

Overall Dimensions

VLQ - SQUARE CROSS SECTION

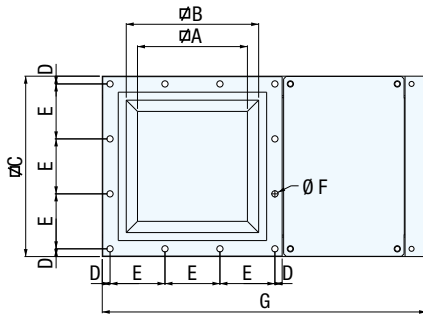

VLC - CIRCULAR CROSS SECTION

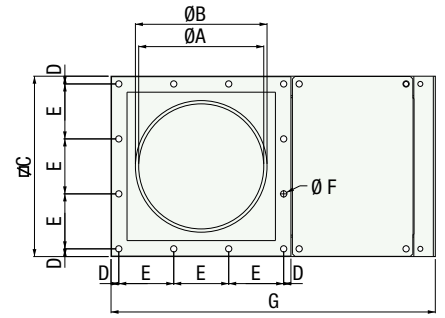

VLS - WITH INTEGRATED PNEUMATIC CYLINDER

Lowest possible overall dimensions!

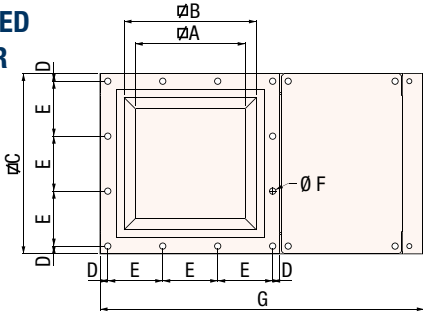

VLR - RECTANGULAR CROSS SECTION

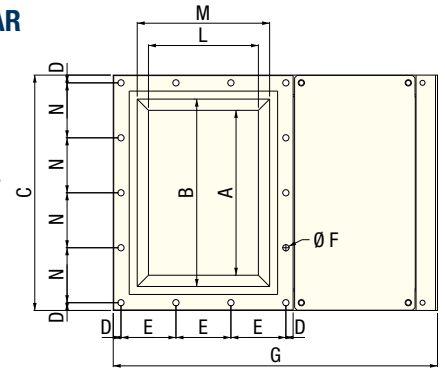
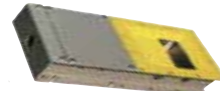

TYPE	A	B	C	D	E	E Nr	Ø F	BOLTS	G	H	kg
VLQ0150..	120	175	261	15	115	2	12	M10	455	113	14.0
VLQ0200..	170	225	311	15	93	3	12	M10	555	113	18.0
VLQ0250..	220	275	361	15	110	3	12	M10	650	113	22.0
VLQ0300..	270	325	431	23	128	3	12	M10	765	113	30.0
VLQ0350..	320	375	481	18	89	5	12	M10	900	125	40.0
VLQ0400..	370	425	531	15	100	5	12	M10	1.000	125	46.0
VLC0150..	150	165	261	15	115	2	12	M10	455	113	14.0
VLC0200..	200	215	311	15	93	3	12	M10	555	113	18.0
VLC0250..	250	265	361	15	110	3	12	M10	650	113	22.0
VLC0300..	300	315	431	23	128	3	12	M10	765	113	30.0
VLC0350..	350	365	481	18	89	5	12	M10	900	125	40.0
VLC0400..	400	415	531	15	100	5	12	M10	1.000	125	46.0
VLS0150..	120	175	261	15	115	2	12	M10	455	113	16.5
VLS0200..	170	225	311	15	93	3	12	M10	555	113	21.0
VLS0250..	220	275	361	15	110	3	12	M10	650	113	25.5
VLS0300..	270	325	431	23	128	3	12	M10	765	113	34.0

TYPE	A	B	C	D	E	E Nr	Ø F	BOLTS	G	H	L	M	N	N Nr	kg
VLR0150..	204	260	346	15.5	115	2	12	M10	455	109	119	175	105	3	18
VLR0200..	281	337	423	15	93	3	12	M10	555	109	169	225	98	4	25
VLR0250..	353	409	495	15	110	3	12	M10	650	109	219	275	116	4	30
VLR0300..	428	484	592	23	128	3	12	M10	765	109	269	325	136	4	40

↑ 1 = mild steel / 3 = 304 stainless steel

Dimensions in mm

Benefits



Low-friction sliding blade fully SINT® polymer-coated in standard version



Abrasion-resistant SINT® engineering polymer



Short delivery time



Few components making maintenance easy



Absence of pinch points and exposed moving parts ensuring safe operation



Technical support and worldwide availability of spare parts thanks to the WAMGROUP® subsidiary network

Technical Features

- Horizontal or vertical mounting
- All round dustproof sealing
- Integrated service inlet deflecting material away from gasket and bearings
- Valve frame entirely coated with SINT® engineering polymer composite (food-grade, FDA-approved on request)
- ATEX certification

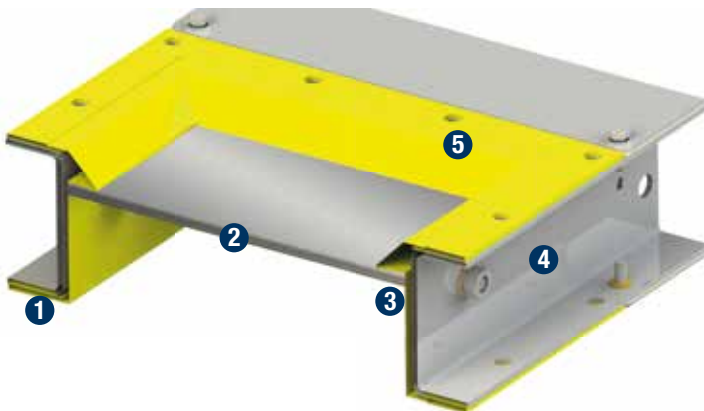

- 1 Valve frame coated with SINT® to avoid product-body contact
- 2 Heavy-duty blade (SINT®, mild steel, 304 stainless steel)
- 3 Minimum friction
- 4 No additional lateral seals required
- 5 Dry food quality (coating in SINT®AL)

Industries



Animal Feed Milling



Plastics Processing



Dry-Mix Processing



Bakeries



Flour Milling



Cosmetics



Environmental Technology



Chemicals



Ceramics



Glass Processing

Application



ACTUATOR COMPATIBILITY

For further details refer to Technical Catalogue



203001754 April 2021 Rights reserved to modify technical specifications.

This brochure has been edited for distribution in European Union countries.



www.wamgroup.com