

Paint & Varnish Processing

Pinch Valves VM / Pipe Connections KAT



22



Description ▼

The casing of the VM Pinch Valve is manufactured from aluminium alloy. Sleeves are made from fabric-reinforced NR or NBR. The sleeve support bushes are either made from aluminium alloy or 304/316 stainless steel.

Function ▼

VM-type Pinch Valves are used for interception of the material flow in pneumatic conveying systems, or other pipelines. They can be also installed as a locking device for silo filling pipes. In the open position the internal cross section of the valve is identical with the connecting pipe diameter. By introducing compressed air through the threaded bore into the interior of the valve, the internal flexible sleeve is reshaped in such a way as to hermetically seal the passage.



Application ▼

VM Pinch Valves are mounted between the bottom end of the silo filling pipe and the KAT Pipe Connection for tanker filling. Should any abnormal conditions occur, such as excess pressure inside the silo or overfilling of the latter, the VM Pinch Valve receives command for instantaneous closure, thus safeguarding the silo from any further filling or overpressurization.

Benefits ▼

- ✓ Full bore-through passage without any pressure loss and stagnation points;
- ✓ Low air consumption;
- ✓ Easy and quick sleeve and bush replacement;
- ✓ Sleeves in fabric-reinforced NR;
- ✓ Compact overall dimensions;
- ✓ Lightweight due to valve body in aluminium alloy;
- ✓ No maintenance required except for periodic replacement of the sleeve and the bushes.

Paint & Varnish Processing

Pinch Valves VM / Pipe Connections KAT



Technical Features / Performance ▼

- ▶ Passage diameter 80mm or 100mm (3 or 4 in)
- ▶ Maximum working pressure: 3.5 bar (52 PSI)
- ▶ Maximum inflation pressure: 6.0 bar (90 PSI)
- ▶ Recommended maximum differential pressure: 2.5 bar (37 PSI)
- ▶ Sleeve material: NR
- ▶ Bush material: Aluminium alloy

Overall Dimensions ▼

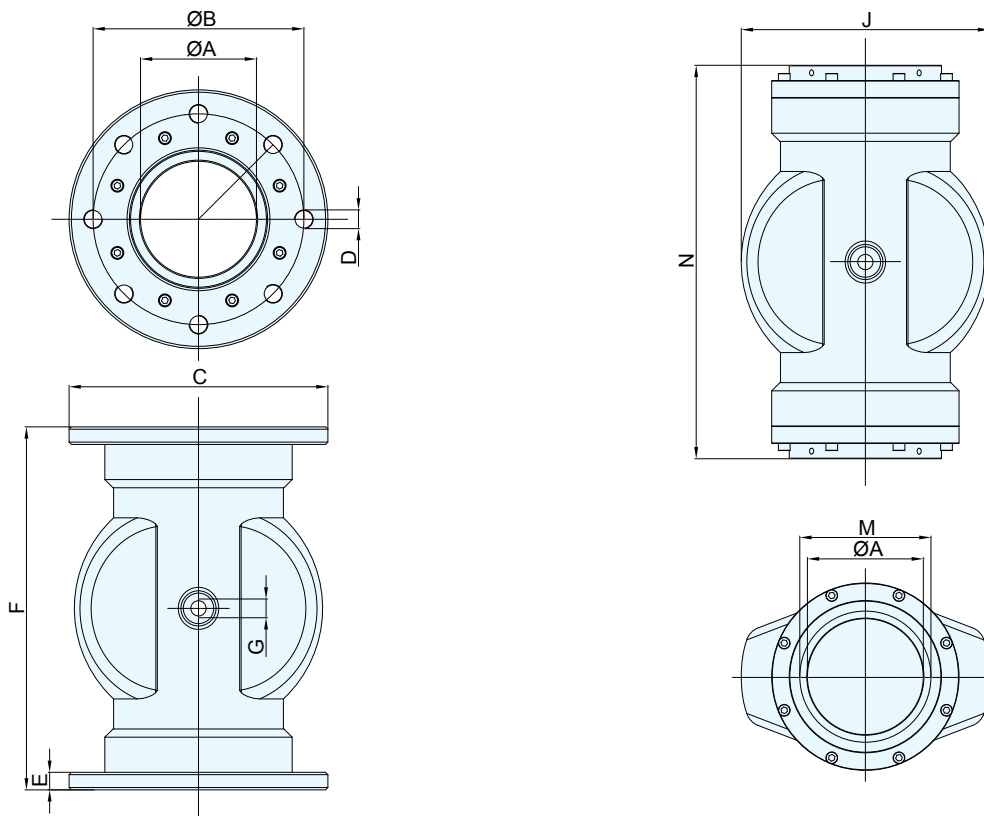

TYPE	A	B	C	D		E	F	G	H	J	L	M	N	kg
				\varnothing	Qty.									
VM080	80	160	200	M 16	4	15	270	1/4"		180		3"	294	5.40
VM0100	100	180	220	M 16	8	15	310	1/4"		214		4"	334	7.60

DS.VM.EH, September, 2015, 000. Rights reserved to modify technical specifications.