

Paint & Varnish Processing

WAMAIR® Dust Collectors FP



9



Description ▼

WAMAIR® FP Dust Collectors consist of a polygonal shape casing, specifically developed for de-dusting mechanical conveyors in Dry-Mix Processing Plants. The filter is equipped with horizontally inserted pocket filter elements and a reverse air jet cleaning system integrated inside the hinged access door.

Function ▼

WAMAIR® Dust Collectors separate dust from the air flow by means of pocket filter elements. The dust drops down after an automatic reverse air jet cleaning device inside the front inspection door has removed it from the filter elements.



Application ▼

WAMAIR® FP Dust Collectors are specially developed for de-dusting mechanical conveyors such as belt conveyors, chain conveyors and bucket elevators.

Benefits ▼

- ✓ Filter dimensions match conveyor shape;
- ✓ Compliance with health and safety standards;
- ✓ Filter elements available in after-market;
- ✓ Safety for both OEM and End User;
- ✓ Running cost reduction;
- ✓ Low energy consumption;
- ✓ Maintenance cost reduction.



Paint & Varnish Processing

WAMAIR® Dust Collectors FP



Technical Features / Performance ▼

- ▶ 304 SS polygonal body
- ▶ Filter surface from 3 to 54m² (32 to 581 sq ft)
- ▶ Low emission level due to B.I.A.-certified filter media
- ▶ Large access door for comfortable filter element removal
- ▶ High cleaning efficiency due to "Full Immersion" solenoid valves integrated in aluminium air tank (corrosion-resistant) for low-maintenance operation
- ▶ High efficiency centrifugal fan
- ▶ Fan integrated in access door

Overall Dimensions ▼

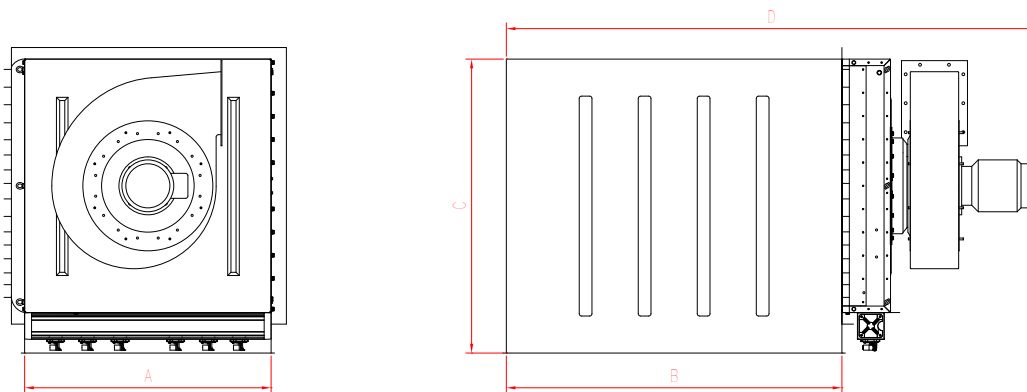

FILTER CODE	FILTER SURFACE (m ²)	A	B	C	D
FPHT 1 03	3	570	700	825	1,570
FPHT 2 05	5	570	950	825	1,820
FPHT 5 09	9	570	1,700	825	2,570
FPHT D 12	12	570	1,200	1,320	2,170
FPHT E 15	15	570	1,450	1,320	2,420
FPHT F 18	18	570	1,700	1,320	2,670
FPHT M 22	22	845	1,450	1,320	2,440
FPHT R 24	24	1,065	1,200	1,320	2,190
FPHT S 30	30	1,065	1,450	1,320	2,530
FPHT T 36	36	1,065	1,700	1,320	2,813
FPHT Y 45	45	1,065	1,450	1,815	2,563
FPHT U 54	54	1,065	1,700	1,815	2,813

Rights reserved to modify technical specifications.

DS.WAMAIR.DEN, September 2015, 800

This datasheet might not show the complete range but only the models specialised for the application.



www.wamgroup.com